

Agilent
U3000A Electronic Instrumentation Training Kit

Data Sheet



Key Features

- **Training board with up to eight selectable modes of operation**
- **Works with four basic test instruments**
- **Comes with teaching materials, lab exercises and assessments**
- **Complete solution for instrumentation teaching**

Solution for Basic Electronic Teaching Lab

The U3000A electronic instrumentation training kit provides a learning and teaching solution for electronic test instruments. With its multiple modes of operation, it offers an interactive learning experience to students. Step-by-step lab exercises enable students and engineers to explore the powerful features of Agilent's instruments. Comprehensive teaching materials on test instruments provide a link between your teaching and learning efforts and the application of electronic test instruments in real-world scenarios. The Agilent U3000A training kit works with four basic instruments: power supply, digital multimeter, digital oscilloscope, and function generator. This makes the training kit an essential tool for your teaching lab.

Training Kit with Power Supply

Power supply is one of the most commonly used tools in design validation and manufacturing tests. The teaching and lab materials help students to better understand the key advantages of various power supply designs and ways to optimize the output.

Training Kit with Digital Multimeter

Agilent offers a wide range of digital multimeters. The Agilent U3000A training kit enhances your students' knowledge of the operation of DMMs. In addition, the students learn techniques that enable them to avoid measurement errors and to carry out fast troubleshooting processes.

Training Kit with Oscilloscope

For those who wish to explore the powerful features of Agilent's oscilloscope, the simulated waveforms and lab exercises of the U3000A will walk you through each function in great detail. Your students can also learn how to select an oscilloscope that meets their needs.

Training Kit with Function Generator

Function generator is an essential tool in design validation. In the lab exercises, your students will learn ways to produce and send various signals to the training board using the Agilent's function generator. With the provided training materials, your students are able to learn operating principles and applications of various types of waveform generators.

Visit www.agilent.com for more information on Agilent's electronic instrumentation training kit

How does the U3000A work with your instruments?

U3000A + Power Supply

The Agilent E3631A triple output power supply is the most recommended model to be operated with U3000A training board. For operation modes 3 through 8, two regulated voltage supplies are required for the Digital-to-Analog converter (ADC) as negative supply ($V_{EE} = -15\text{ V}$) and output voltage reference ($V_{REF} = +10\text{ V}$). The microcontroller processes the input from the ADC in order to generate various types of signals for the lab exercises.

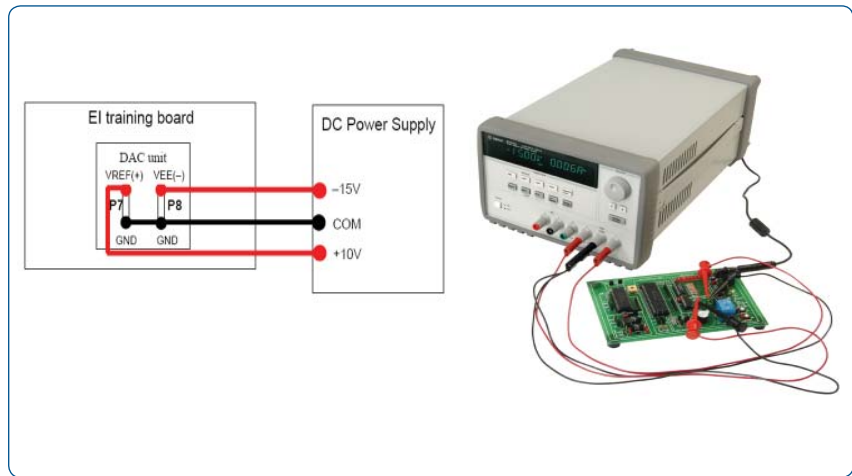

U3000A + Digital Multimeter

The recommended 34405A digital multimeter is used to teach you how to perform voltage, current, resistance, capacitance, frequency, and diode measurements in practice. Use the U3000A training board with the digital multimeter to understand measurement connections and methods.



U3000A + Digital Oscilloscope

The Agilent DSO3000 Series economy oscilloscope represents the best choice when used in combination with the U3000A training board. Going through the provided lab exercises, you will learn to analyze various types of signals or waveforms generated by the U3000A training board, including counter signals, square waves from a 555 timer, irregular pulse waves, triangular waves, and sinusoidal waves.

The automatic measurement functions of the oscilloscopes allow you to make and display any or all different measurements simultaneously. In addition, you will also learn to display a waveform in a frequency domain using the Fast Fourier Transform (FFT) function and to filter a mixed sinusoidal signal using the digital filtering technique.

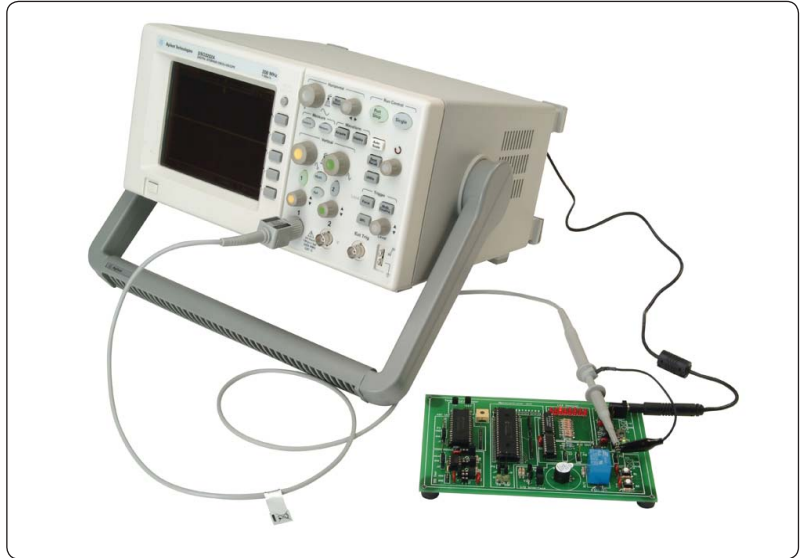

U3000A + Function Generator

The U3000A training board consists of an on-board timer and a crystal oscillator. The provided lab exercises guide you through the necessary steps to generate input signals using the Agilent 33220A function generator, to replace the on-board timer and microcontroller's clock. You are enabled to control the microcontroller's clock using the 33220A function generator and to observe the resulting output from the U3000A training board.

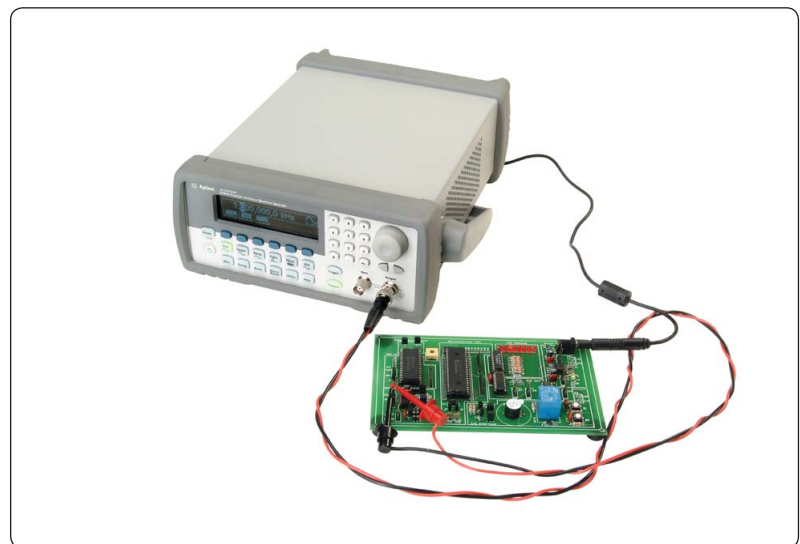

Modes of Operation

Mode 1:

Temperature monitoring by comparing a precision input temperature sensor and a reference temperature sensor. The 8-bit ADC data of the input temperature is displayed in an 8-bit LED display. If the input temperature is higher than the reference temperature, the buzzer will be triggered.

Mode 2:

Temperature monitoring simulation using a potentiometer and a reference temperature sensor. The 8-bit ADC data of the potentiometer is displayed in an 8-bit LED display. The potentiometer is adjustable from 0 V to 5 V, which acts as an input to be compared with the reference temperature. If the input voltage is higher than the ADC voltage of the reference temperature, the buzzer will be triggered.

Mode 3:

Generating an incremental counter signal, a slow varying sawtooth signal with approximately 0.8 Hz to 48 Hz (adjustable using a potentiometer). The Digital-to-Analog Converter (DAC) yields an output voltage of 256 levels between 0 V to 4.98 V, see Figure 1.

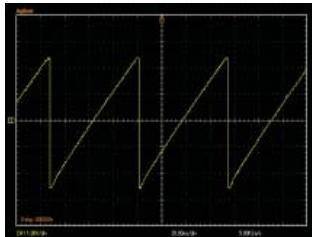

Figure 1 An Incremental Counter Signal

Mode 4:

Generating a 5 V triangular wave with approximately 0.4 Hz to 48 Hz (adjustable using potentiometer), see Figure 2.

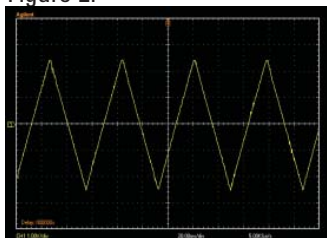

Figure 2 A 5V Triangular Wave

Mode 5:

Generating a 1.6 V square wave with approximately 52 Hz to 7 kHz (adjustable using a potentiometer), see Figure 3.

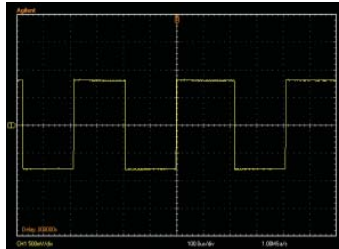

Figure 3 A 1.6 V Square Wave Signal

Mode 6:

Generating a 5 V irregular pulse wave with period of approximately 0.4 Hz to 48 Hz and a total width of 2.6 ms to 300 ms (adjustable using a potentiometer), see Figure 4.

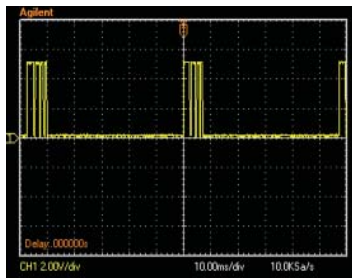

Figure 4 A 5 V Irregular Pulse Signal

Mode 7:

Generating a 5 V sinusoidal wave with approximately 0.4 Hz to 48 Hz (adjustable using a potentiometer), see Figure 5.

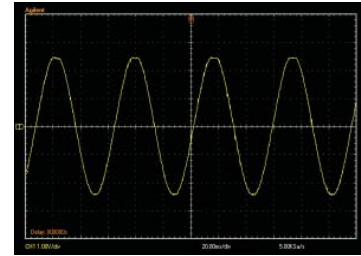

Figure 5 A 5V Sinusoidal Signal

Mode 8:

Generating a mixed sinusoidal signal with digital noise, see Figure 6. The maximum achievable frequencies are approximately 4.2 kHz and 6.2 kHz. The digital noise can be filtered using digital scope filtering.

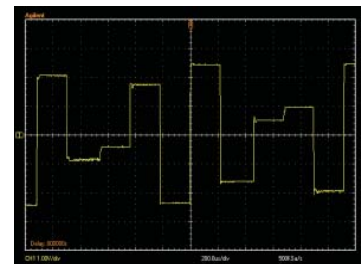

Figure 6 Mixed Sinusoidal Signal with Digital Noise

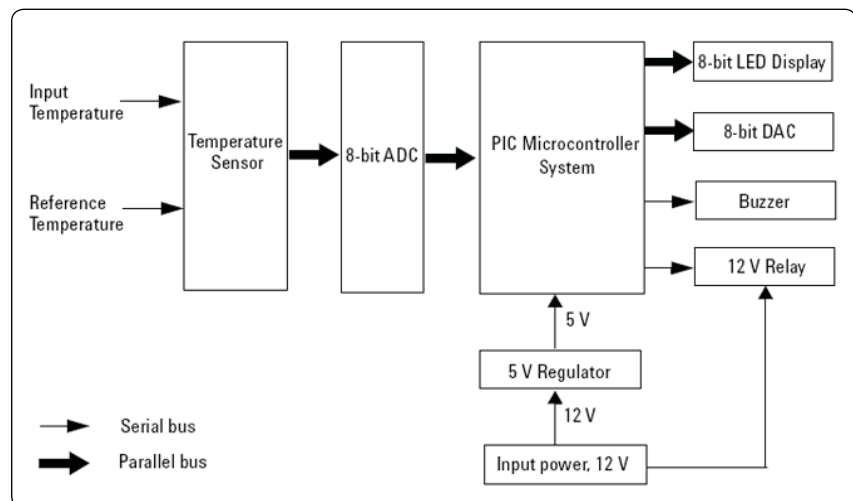

Figure 7 Block Diagram of U3000A Electronic Instrumentation Training Kit

Teaching Modules

Power supply teaching material coverage

- Power supply design overview
- Advantages and disadvantages of linear power supplies and switching power supplies
- Operating principle of DC-DC converters
- Methods of power supply protection
- Basic principle of linear power supply — operating modes, unwanted signals, unregulated states, remote programming
- Practical tips to optimize power supply capability for different applications

Digital multimeter teaching material coverage

- Basic functions of digital multimeter
- Operating principles of the basic functions
- Measurement errors overview
- Advanced functions that simplify common measurement tasks
- Circuit fault finding with digital multimeter

Digital oscilloscope teaching material coverage

- Basic functions of digital oscilloscope
- Types of oscilloscopes
- Digital oscilloscope parameters overview
- Performing measurements with digital oscilloscopes
- Tips for selecting your ideal digital oscilloscope

Function generator teaching material coverage

- Operating principles of the function generator
- Comparison of function generator and arbitrary waveform generator
- Function generator design and operating principles
- Applications of the function generator

Lab Exercises

Power supply lab exercises

- Rated voltage and current settings check
- Voltage and current measurement in Constant Voltage (CV) and Constant Current (CC) modes
- Waveform analysis with power supply to training board

Digital multimeter lab exercises

- Voltage and current measurements
- Resistance, capacitance, frequency, and diode measurements

Digital oscilloscope lab exercises

- Waveform measurements
- Digital noise filtering

Function generator lab exercises

- Modulated waveform generation
- Waveform generation to training board
- Frequency sweep generation

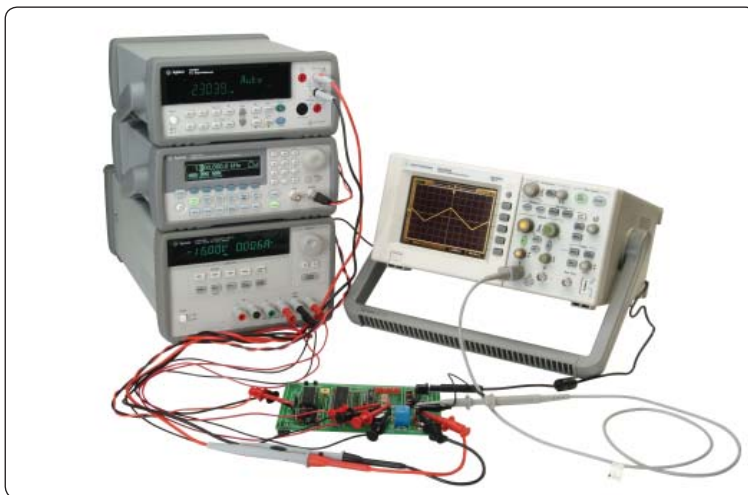

GENERAL SPECIFICATIONS

POWER SUPPLY

Line voltage range 50/60 Hz, 100 VAC to 240 VAC

POWER ADAPTER

Output voltage 12 VDC

OPERATING ENVIRONMENT

Operating temperature at 0 °C to 40 °C
Up to 95% RH at 40 °C (non-condensing)
Altitude up to 2000 meters

STORAGE COMPLIANCE

-40 °C to 70 °C

SAFETY

Certified to IEC61010-1:2001/EN61010-1:2001
Pollution degree 2
This product is rated for indoor use only.

EMC

IEC 61326:2002/EN61326:1997+A1:1998+A2:2001+A3:2003

DIMENSIONS (HxWxD)

26 mm x 172 mm x 118 mm

WEIGHT

0.12 kg

WARRANTY

3 months

Accessories included:

- Mini grabbers/banana jacks
- Power cord
- AC power adaptor
- U3000A Quick Start Guide
- Product Reference CD-ROM

Experience the new Agilent U3000A
electronic instrumentation training kit.

Learn more about the training kit from
the U3000A homepage at
www.agilent.com/find/educationkit.





Agilent Email Updates

www.agilent.com/find/emailupdates

Get the latest information on the products and applications you select.



Agilent Direct

www.agilent.com/find/agilentdirect

Quickly choose and use your test equipment solutions with confidence.



www.agilent.com/find/open

Agilent Open simplifies the process of connecting and programming test systems to help engineers design, validate and manufacture electronic products. Agilent offers open connectivity for a broad range of system-ready instruments, open industry software, PC-standard I/O and global support, which are combined to more easily integrate test system development.

Remove all doubt

Our repair and calibration services will get your equipment back to you, performing like new, when promised. You will get full value out of your Agilent equipment throughout its lifetime. Your equipment will be serviced by Agilent-trained technicians using the latest factory calibration procedures, automated repair diagnostics and genuine parts. You will always have the utmost confidence in your measurements.

Agilent offers a wide range of additional expert test and measurement services for your equipment, including initial start-up assistance onsite education and training, as well as design, system integration, and project management.

For more information on repair and calibration services, go to

www.agilent.com/find/removealldoubt

www.agilent.com

For more information on Agilent Technologies' products, applications or services, please contact your local Agilent office. The complete list is available at:

www.agilent.com/find/contactus

Phone or Fax

United States:

(tel) 800 829 4444
(fax) 800 829 4433

Canada:

(tel) 877 894 4414
(fax) 800 746 4866

China:

(tel) 800 810 0189
(fax) 800 820 2816

Europe:

(tel) 31 20 547 2111

Japan:

(tel) (81) 426 56 7832
(fax) (81) 426 56 7840

Korea:

(tel) (080) 769 0800
(fax) (080) 769 0900

Latin America:

(tel) (305) 269 7500

Taiwan:

(tel) 0800 047 866
(fax) 0800 286 331

Other Asia Pacific Countries:

(tel) (65) 6375 8100
(fax) (65) 6755 0042
Email: tm_ap@agilent.com
Revised: 11/08/06

Product specifications and descriptions in this document subject to change without notice.

© Agilent Technologies, Inc. 2007
Printed in USA, October 23, 2007
5989-6503EN



Agilent Technologies