

# Power Measurement Basics



**Adolfo Del Solar**

Application Engineer  
[adolfo\\_del-solar@agilent.com](mailto:adolfo_del-solar@agilent.com)



**Agilent Technologies**

# Agenda

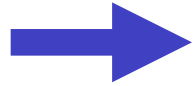

- Importance of Power Measurements
- Average, Peak and Pulse Power
- Power Meter & Sensor Measurement Method
- Sensor Technologies
- Agilent Power Measurement Solutions
- Time-Gated Power Measurements
- Advanced Power Measurements
- Measurement Uncertainty



# Signal Power Levels are Critical

**Too low:**

***Signal buried in noise***

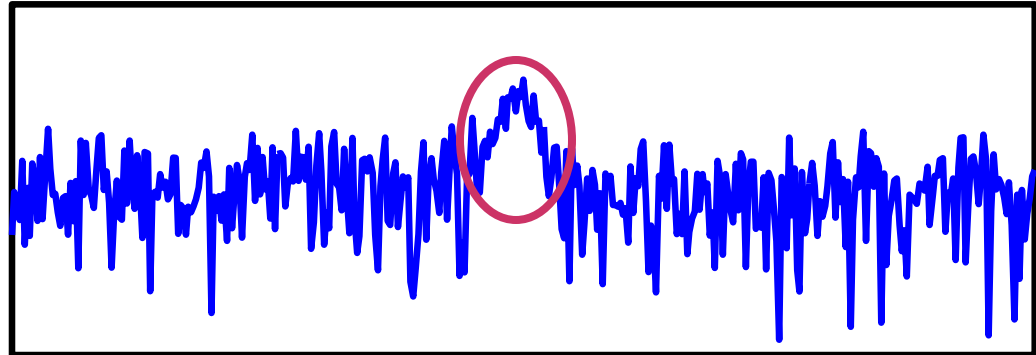

**Too high:**

***Nonlinear distortion...***

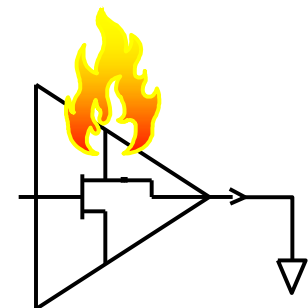
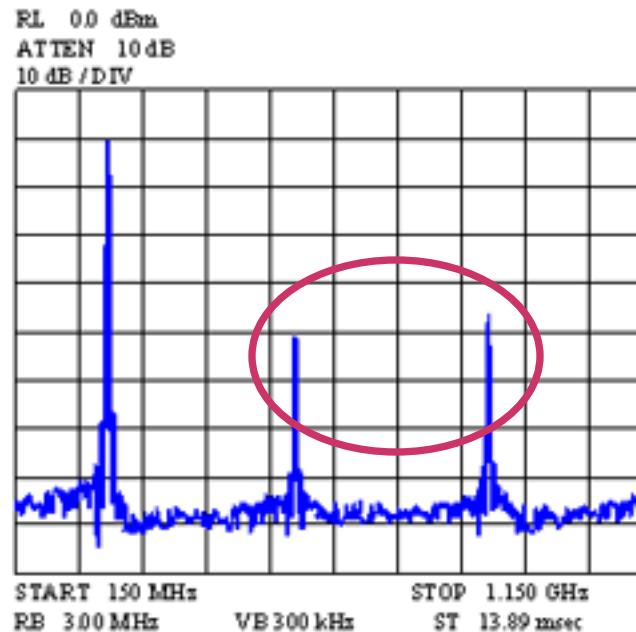

***...Or even worse!***



# Why Not Measure Voltage?

## DC

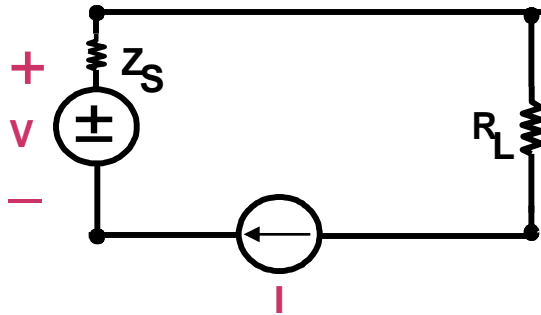

$$P = IV = V^2/R$$

## Low Frequency

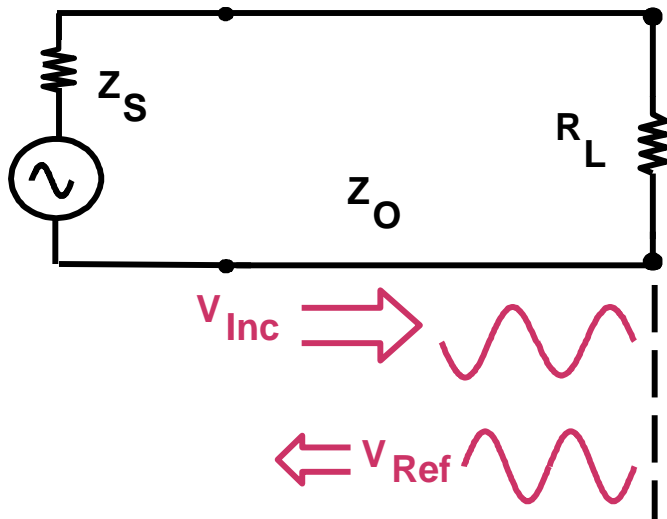
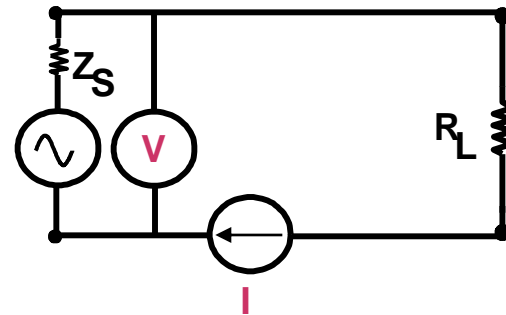

## High Frequency

- **I** and **V** vary with position
- **Power is constant**

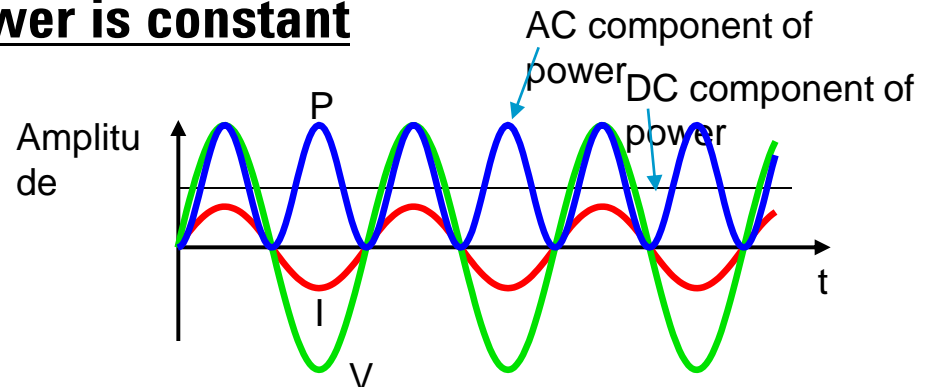

# Agenda

- Importance of Power Measurements
- • Average, Peak and Pulse Power
- Power Meter & Sensor Measurement Method
- Sensor Technologies
- Agilent Power Measurement Solutions
- Time-Gated Power Measurements
- Advanced Power Measurements
- Measurement Uncertainty



# Average Power

**AM**

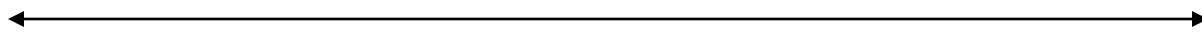
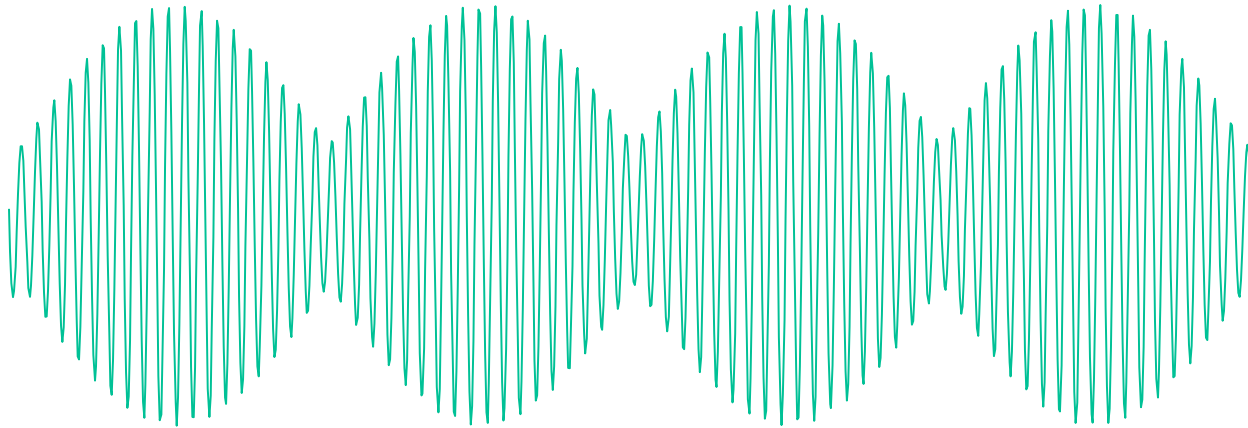

Average over many modulation cycles

**Pulsed**

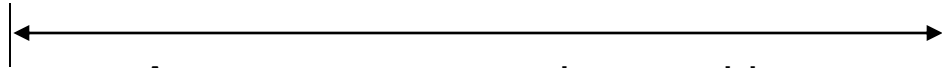
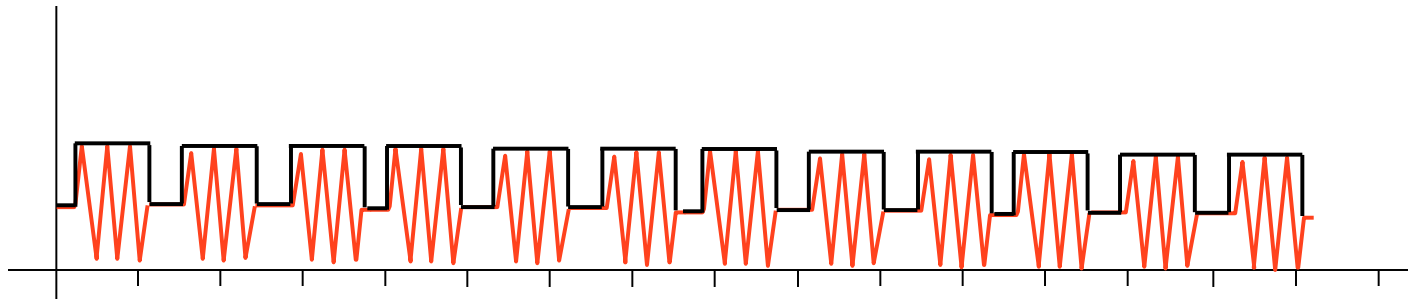

Average over many pulse repetitions

t



# Pulse Power

Pulse Power = Average Power/Duty Cycle

- Rectangular pulse
- Constant duty cycle

Power

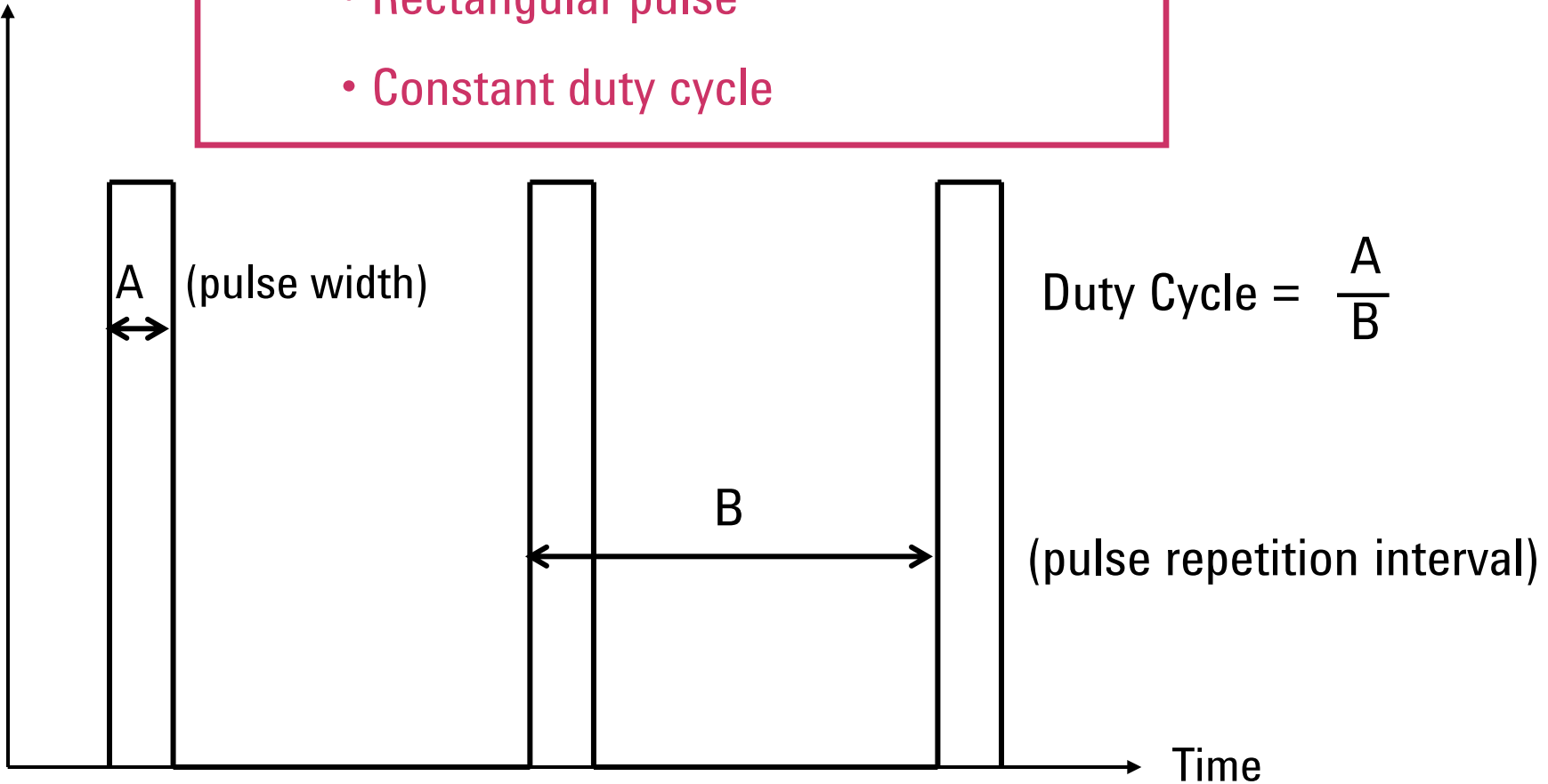

# Envelope Power and Peak Envelope Power

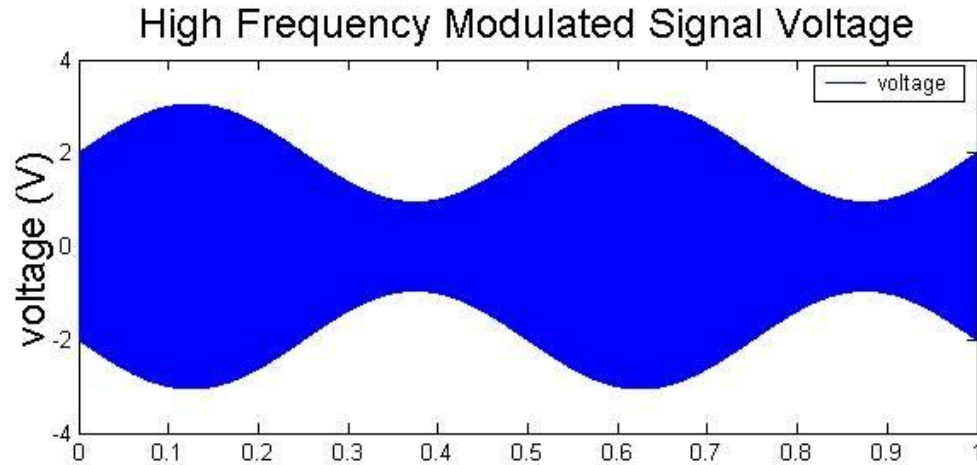

Instantaneous  
Power

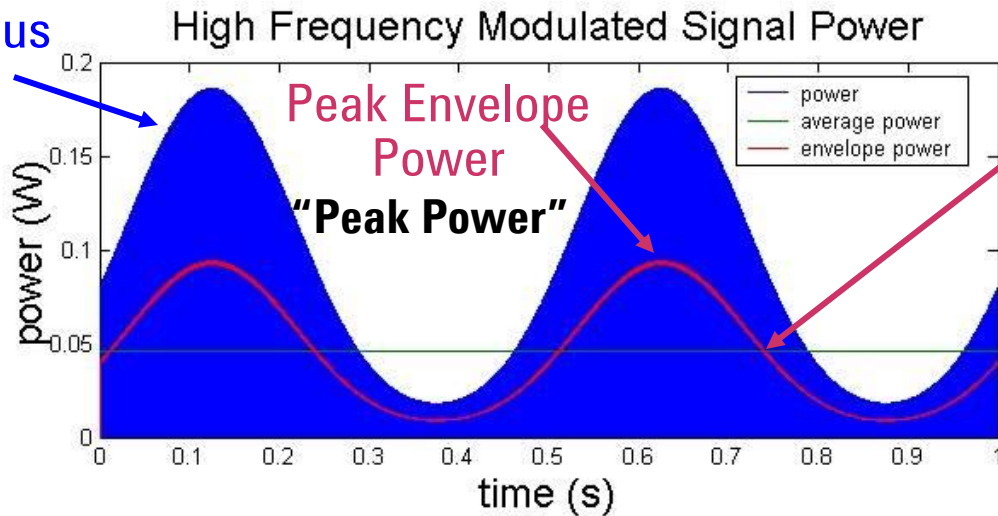

# Agenda

- Importance of Power Measurements
- Average, Peak and Pulse Power
- ➔ • Power Meter & Sensor Measurement Method
- Sensor Technologies
- Agilent Power Measurement Solutions
- Time-Gated Power Measurements
- Advanced Power Measurements
- Measurement Uncertainty



# Instruments That Measure RF & Microwave Power

## Power Meter and Sensor



- $\pm 0.0X$  dB
- $\geq -70$  dBm

## Network Analyzer



- $\pm 0. X$  dB or greater
- Frequency selective

## Vector Signal Analyzer



## Spectrum Analyzer

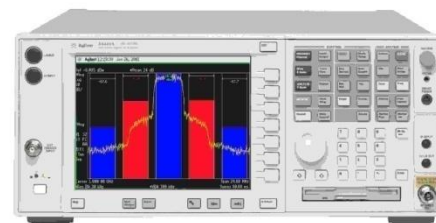

# The Power Meter and Sensor Method

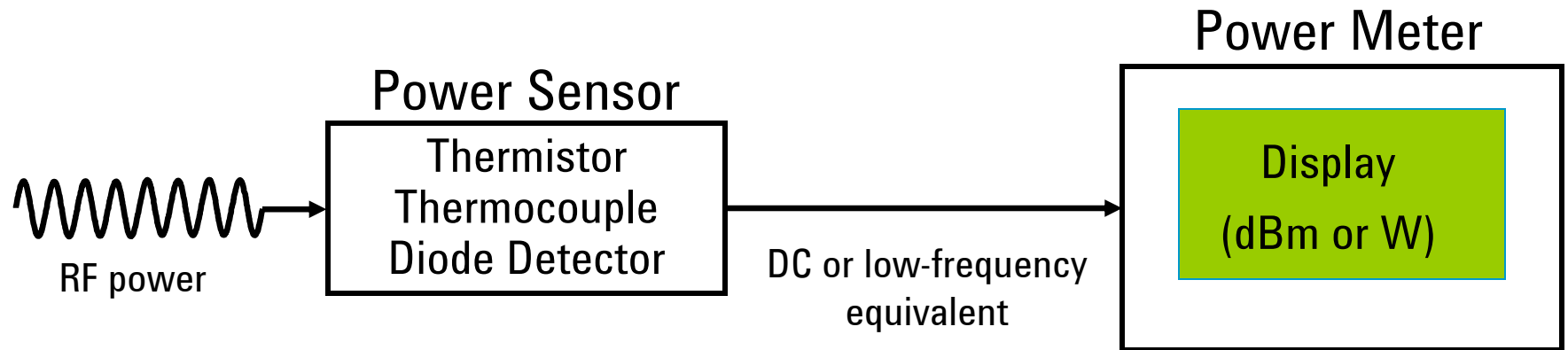

# Agenda

- Importance of Power Measurements
- Average, Peak and Pulse Power
- Power Meter & Sensor Measurement Method
- • Sensor Technologies
- Agilent Power Measurement Solutions
- Time-Gated Power Measurements
- Advanced Power Measurements
- Measurement Uncertainty



# Thermistors

- One of the earliest types of power sensors
- Have been replaced in most applications by thermocouples and diode detectors
- Still used for power transfer standards in metrology applications



# Thermocouples

- A junction of two dissimilar metals generates a voltage related to temperature
- Junction temperature is directly related to RF power

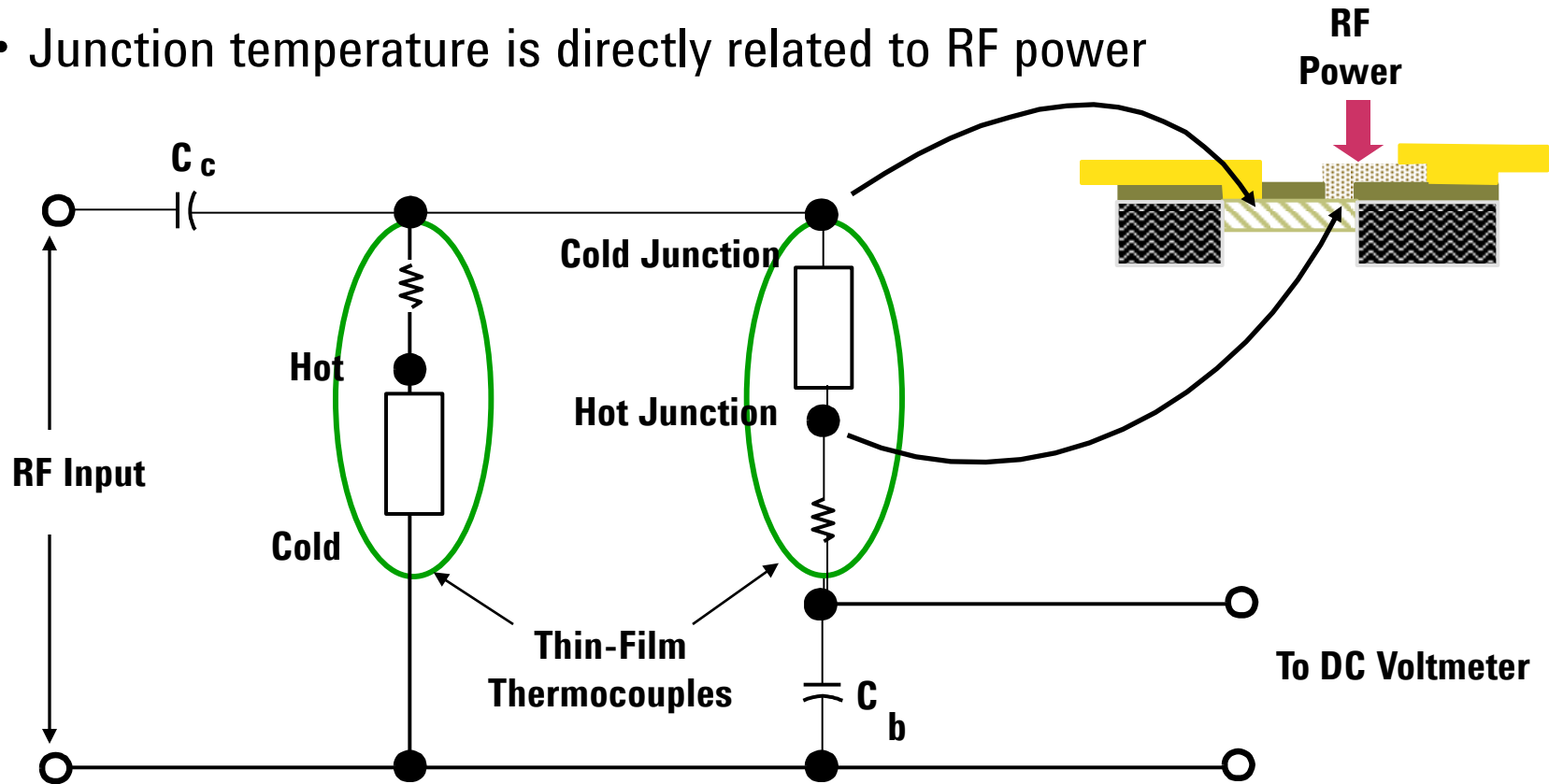

# Diode Detectors

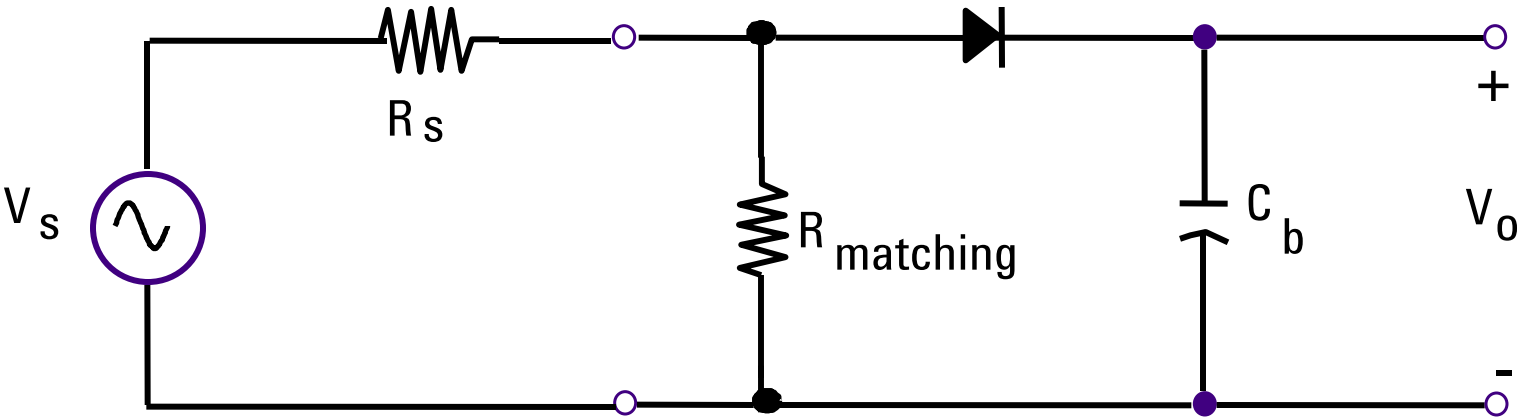

# Agenda

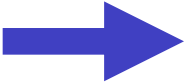
- Importance of Power Measurements
- Average, Peak and Pulse Power
- Power Meter & Sensor Measurement Method
- Sensor Technologies
-  • Agilent Power Measurement Solutions
- Time-Gated Power Measurements
- Advanced Power Measurements
- Measurement Uncertainty



# P-Series and EPM-P Series Power Meters

- **P-Series Power Meters**

- Peak, average, peak-to-average ratio; time-gated measurements; rise time, fall time and pulse width; 30 MHz video bandwidth (N1911A/12A)



- **N8262A P-Series Modular Power Meter**

- Equivalent N1912 performance with slim (1U) form factor; LXI-C compliant



- **EPM-P Series Power Meters**

- Peak, average, peak-to-average ratio; time-gated measurements, 5 MHz video bandwidth (E4416A/17A)



# Thermistor, HH and EPM Series Power Meters

- **N432A Thermistor Power Meter**

- Average measurements for metrology and calibration laboratory environments; built-in calibration factor table. LXI-C compliant.



- **V3500A Handheld RF Power Meter**

- Built-in power sensor with self calibration; powered by batteries, an AC-DC converter module, or a computer via USB interface



- **EPM Series Power Meters**

- Average power measurements (N1913A/14A)



# 8480, E-Series and P-Series Power Sensors

- **8480 and N8480 Series (Therm. and Diode)**
  - Average power from  $-70$  to  $+44$  dBm; 100 kHz to 110 GHz; unlimited video BW
  - Typical dynamic range of 50 dB
- **E-Series (Diode)**
  - **E441X**: 90 dB dynamic range; CW only
  - **E9300**: 80 dB dynamic range; average power of any signal type; no BW limitation
  - **E9320**: peak and average power from 50 MHz to 18 GHz; 5 MHz video BW
- **P-Series (Diode)**
  - **N192XA**: peak and average from 50 MHz to 40 GHz; 30 MHz video BW



# U2000 Series USB Average Power Sensors

- **U2000A/B/H**
  - 80 dB dynamic range; 10 MHz to 18 GHz
- **U2001A/B/H**
  - 80 dB dynamic range; 3 MHz to 6 GHz
- **U2002A/H**
  - 80 dB dynamic range; 50 MHz to 26,5 GHz
- **U2004A**
  - 80 dB dynamic range; 9 kHz to 6 GHz

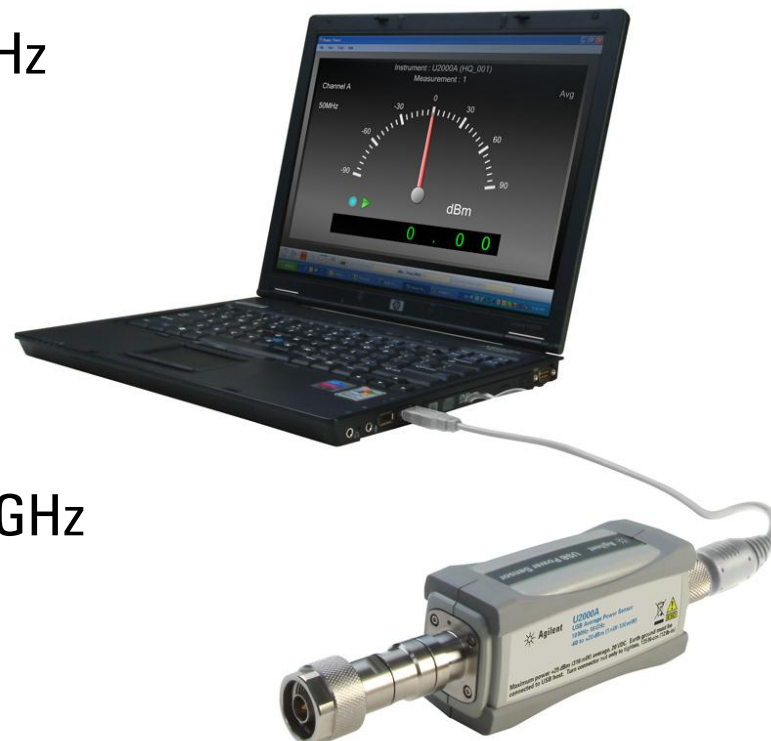

# P-Series Power Sensors Internal Zero and Cal

**Internal zero and calibration** within the N1921A/22A sensors - eliminates multiple connections with external calibration source

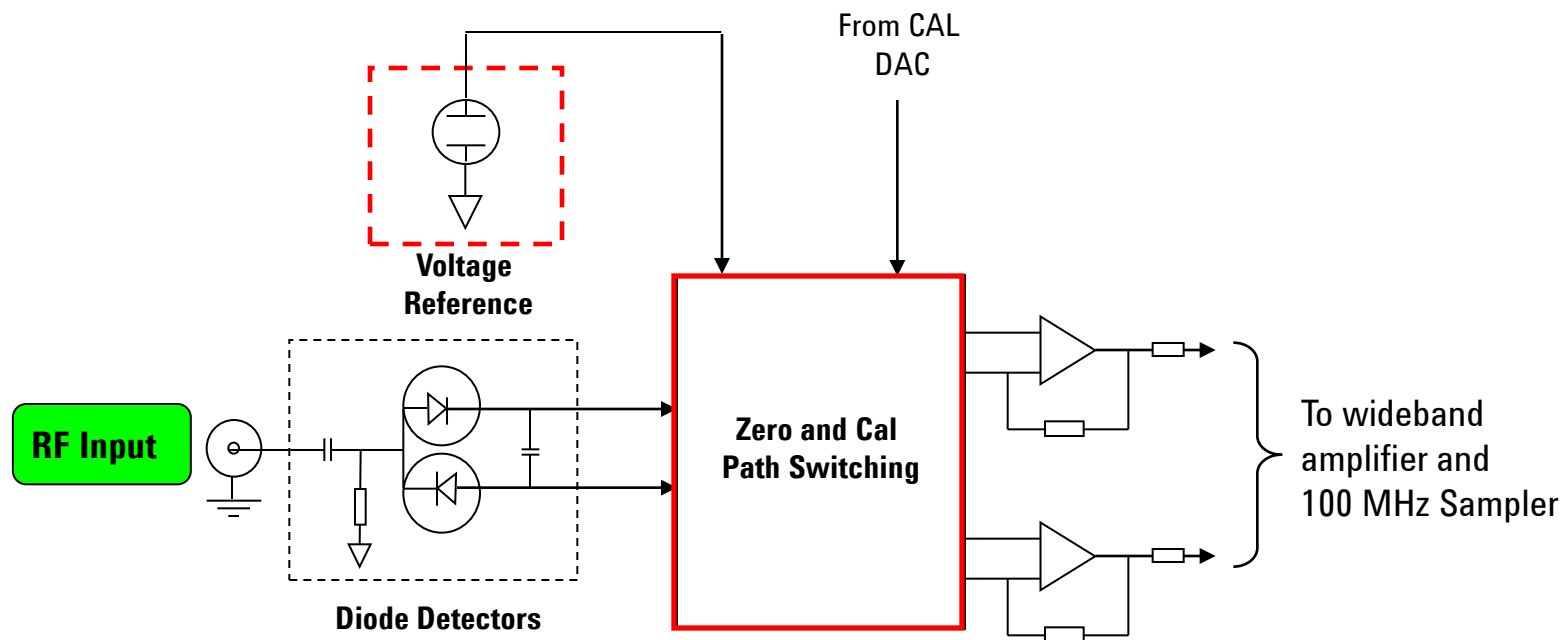

**N192XA Wideband Power Sensor Block Diagram**

# Agenda

- Importance of Power Measurements
- Average, Peak and Pulse Power
- Power Meter & Sensor Measurement Method
- Sensor Technologies
- Agilent Power Measurement Solutions
-  • Time-Gated Power Measurements
- Advanced Power Measurements
- Measurement Uncertainty



# Time-Gated Power Measurements

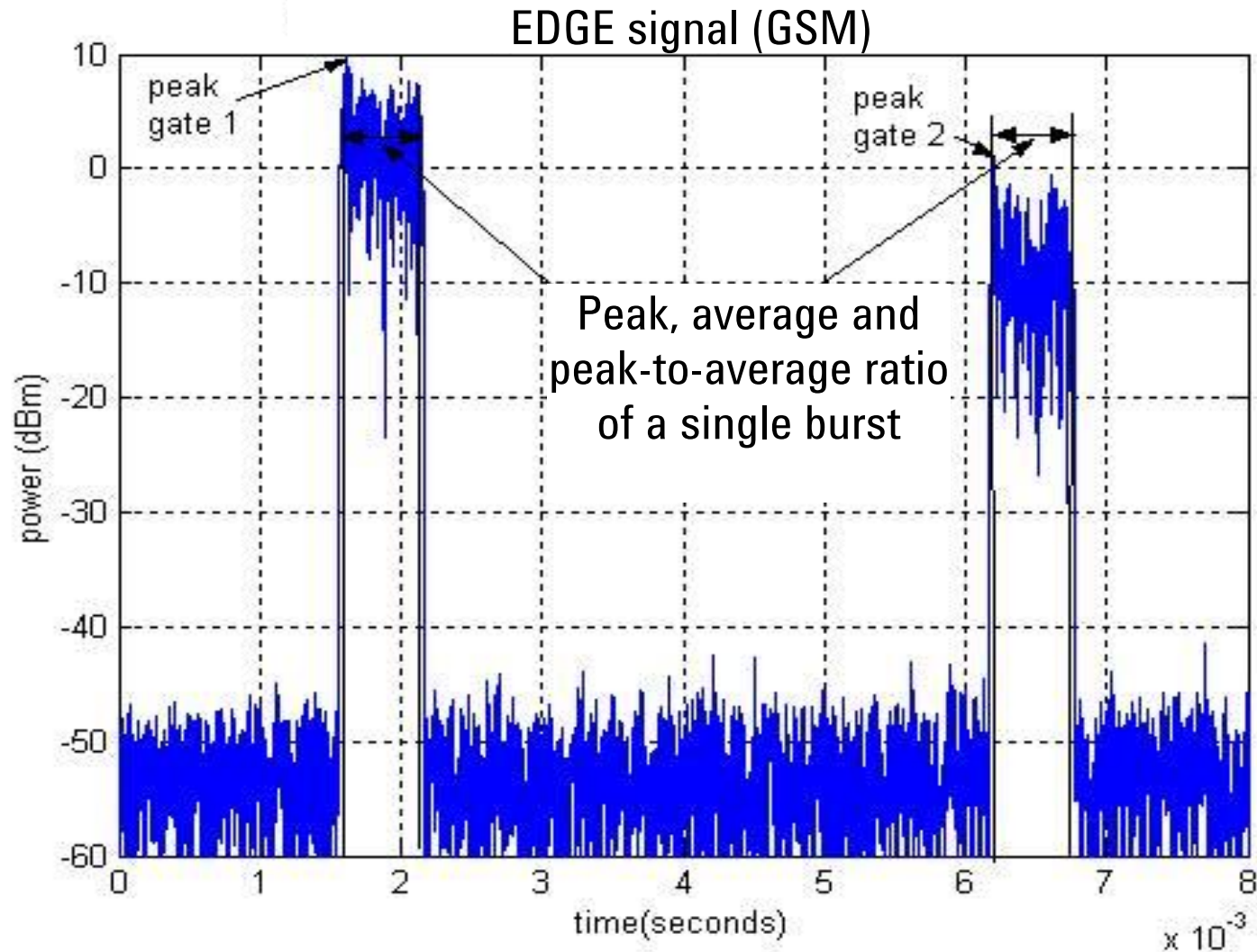

# Sensors for Time-Gated Measurements

- **Sensor rise/fall time requirements**
  - For characterizing overshoot:  $\leq 1/8$  signal rise time
  - For average power: same as signal rise time
- **E9320 peak/average sensors**
  - 200 ns rise time (typical)
  - TDMA, CDMA and W-CDMA wireless formats
- **P-Series wideband power sensors**
  - $\leq 13$  ns rise time and fall time
  - Radar and pulsed component test



# Triggering and Measurement Capabilities

## EPM-P and P-Series Power Meters

Ext Trigger

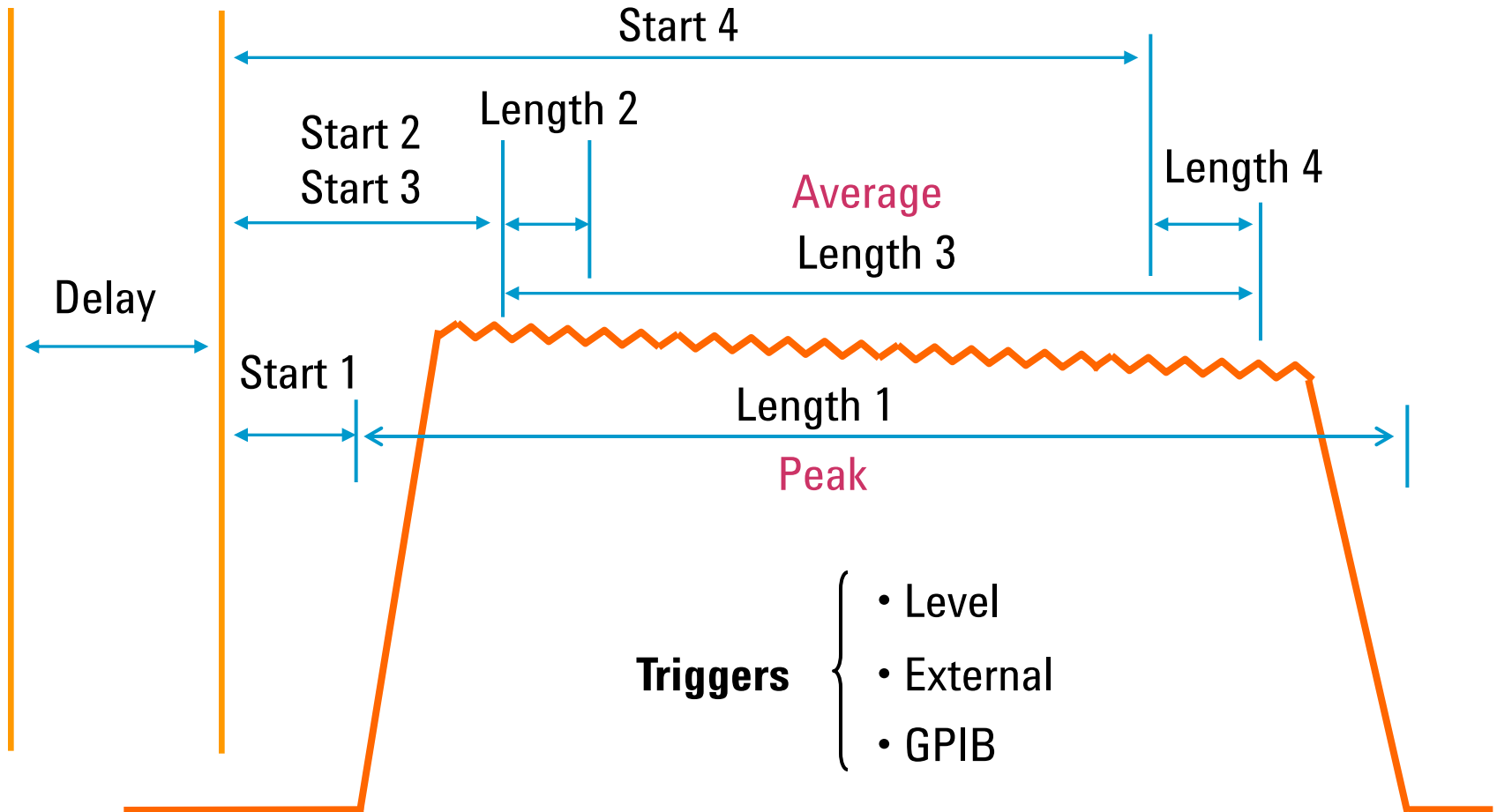

# Agenda

- Importance of Power Measurements
- Average, Peak and Pulse Power
- Power Meter & Sensor Measurement Method
- Sensor Technologies
- Agilent Power Measurement Solutions
- Time-Gated Power Measurements
- ➔ • Advanced Power Measurements
- Measurement Uncertainty



# Technology Drivers

- **Aerospace and Defence (Radar)**
- **Digital Wireless Communications**

**GSM (0.3 GMSK)**

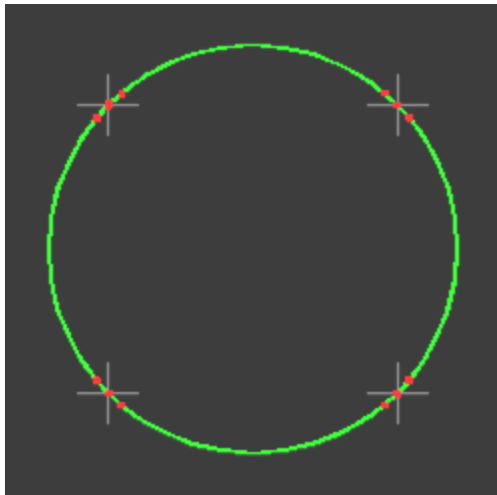

- TDMA system
- Time-gated average power
- Fast measurements

**EDGE ( $3\pi/8$  Shifted 8PSK)**

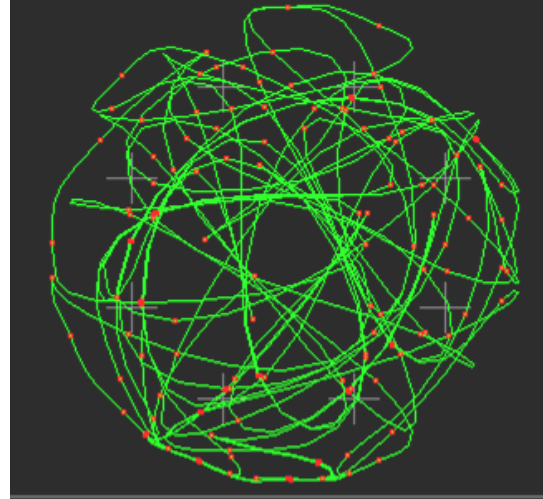

- High-speed data transfer

**cdma2000**

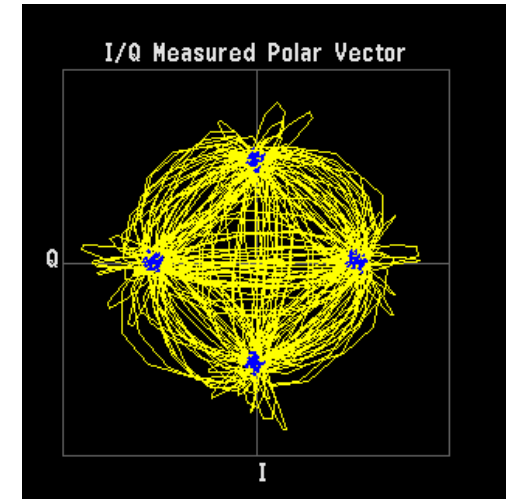

- 3G technology
- Peak-to-average ratio
- CCDF



# Wide Bandwidth and Fast, Continuous Sampling

- **P-Series Power Meters and Sensors**
  - 30 MHz video bandwidth up to 40 GHz
  - Continuous sampling at 100 Msample/s

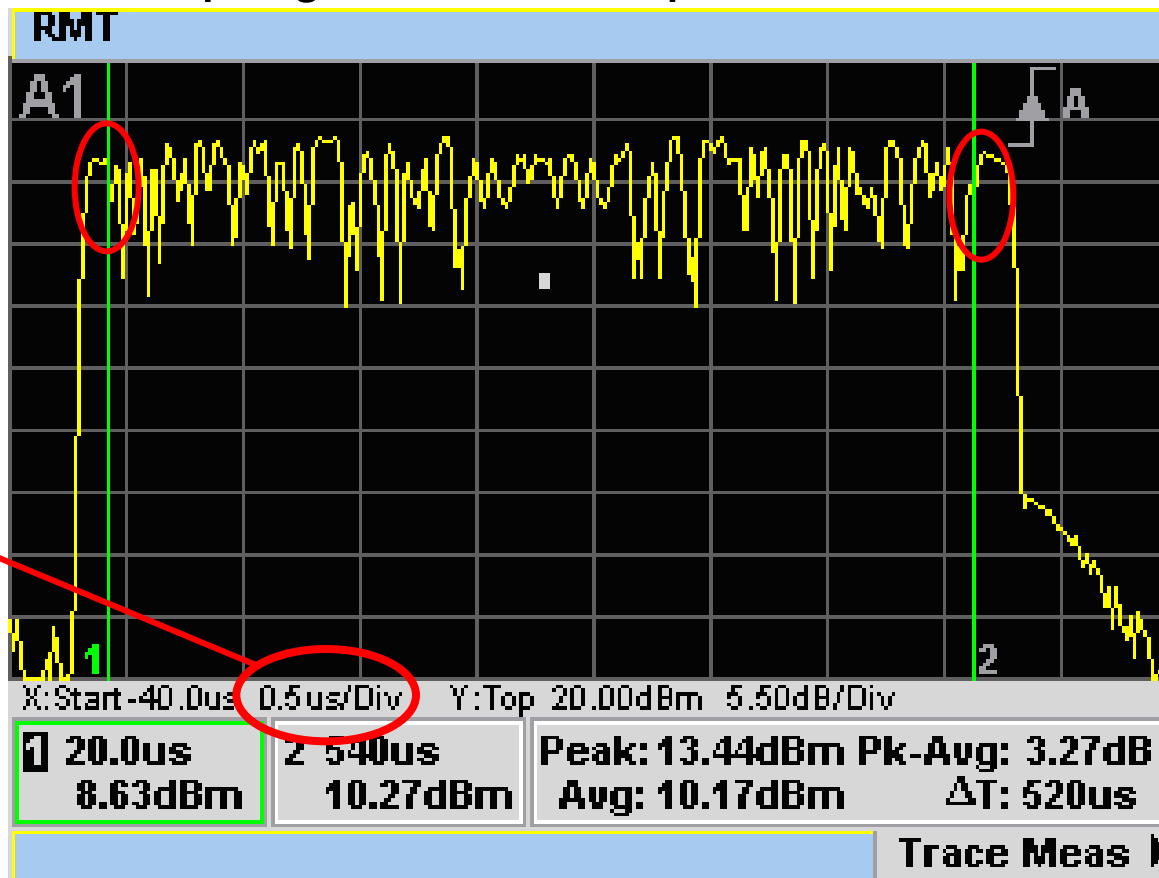

# P-Series Power Meters and Sensors



- **Key Measurements**

- Peak, average, peak-to-average ratio; rise time, fall time and pulse width; time-gated and free-run measurements



# P-Series Measurement Display

- Graphical trace setup
- Marker measurements and analysis

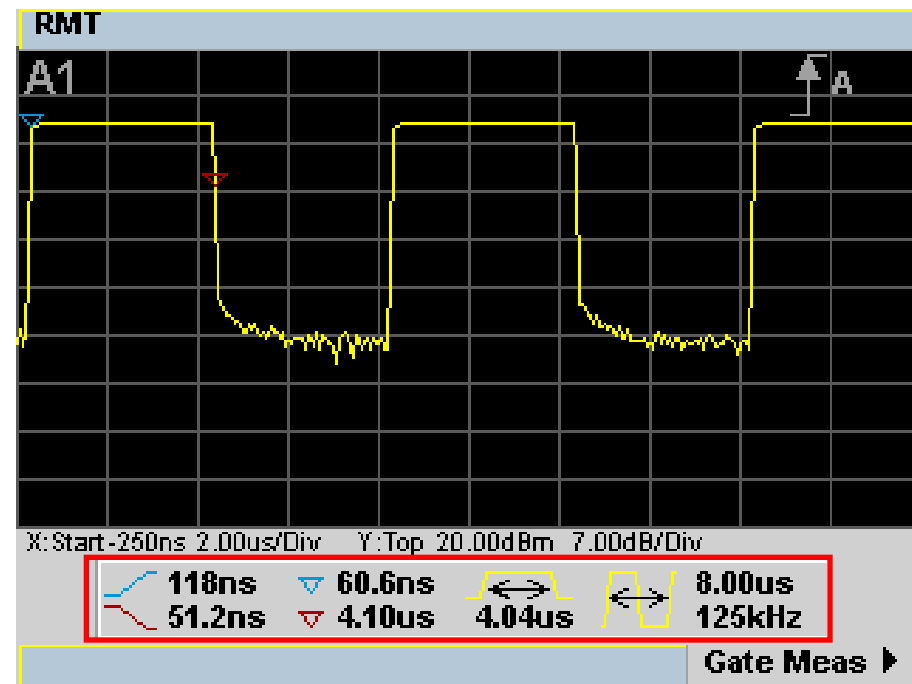
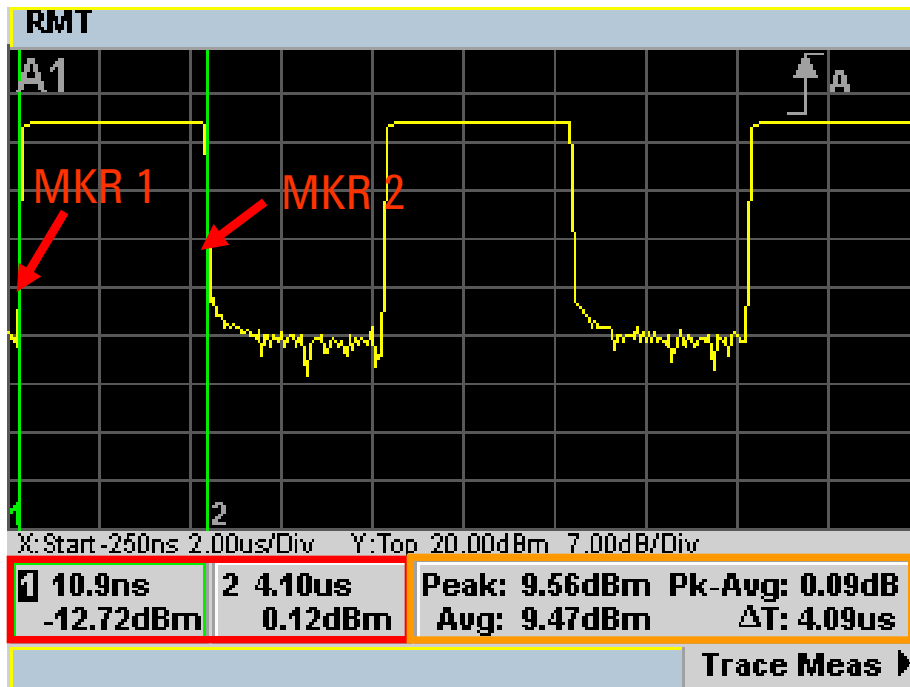

# Agenda

- Importance of Power Measurements
- Average, Peak and Pulse Power
- Power Meter & Sensor Measurement Method
- Sensor Technologies
- Agilent Power Measurement Solutions
- Time-Gated Power Measurements
- Advanced Power Measurements
- • Measurement Uncertainty



# Sources of Power Measurement Uncertainty

- **Sensor and Source Mismatch Errors**
- **Power Sensor Errors**
- **Power Meter Errors**

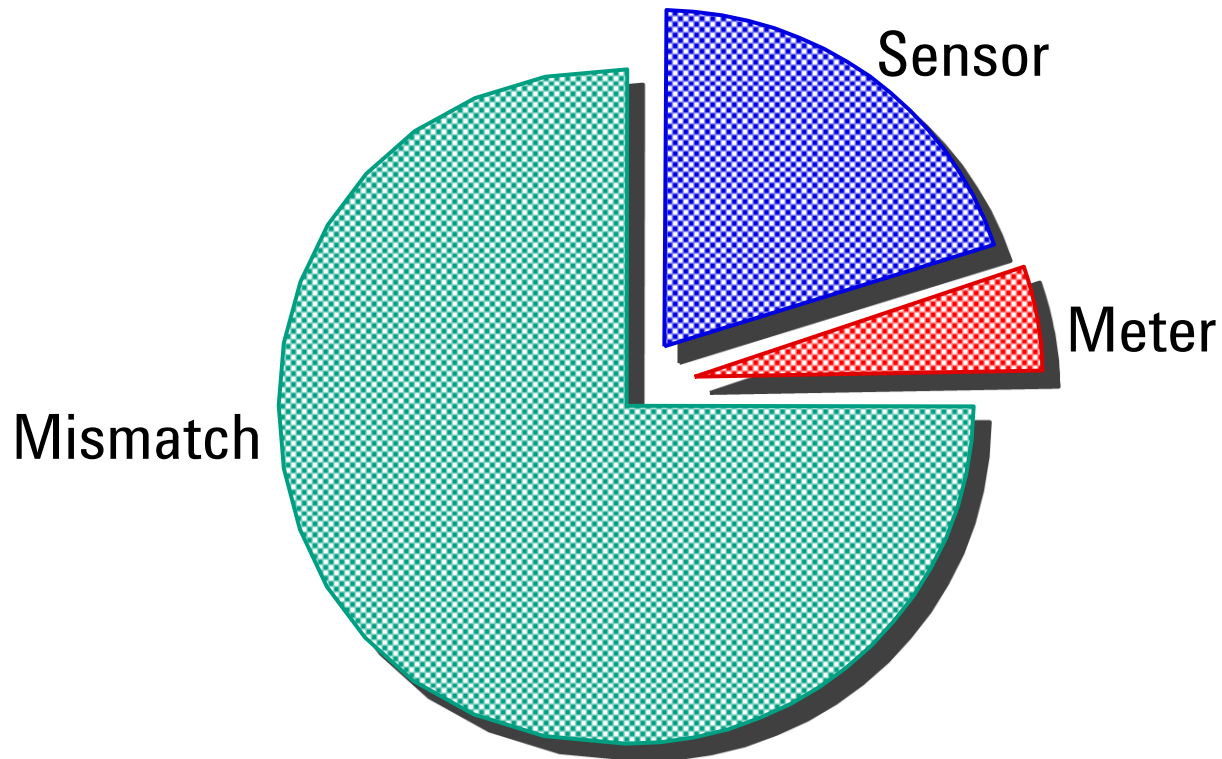

# Sensor and Source Mismatch

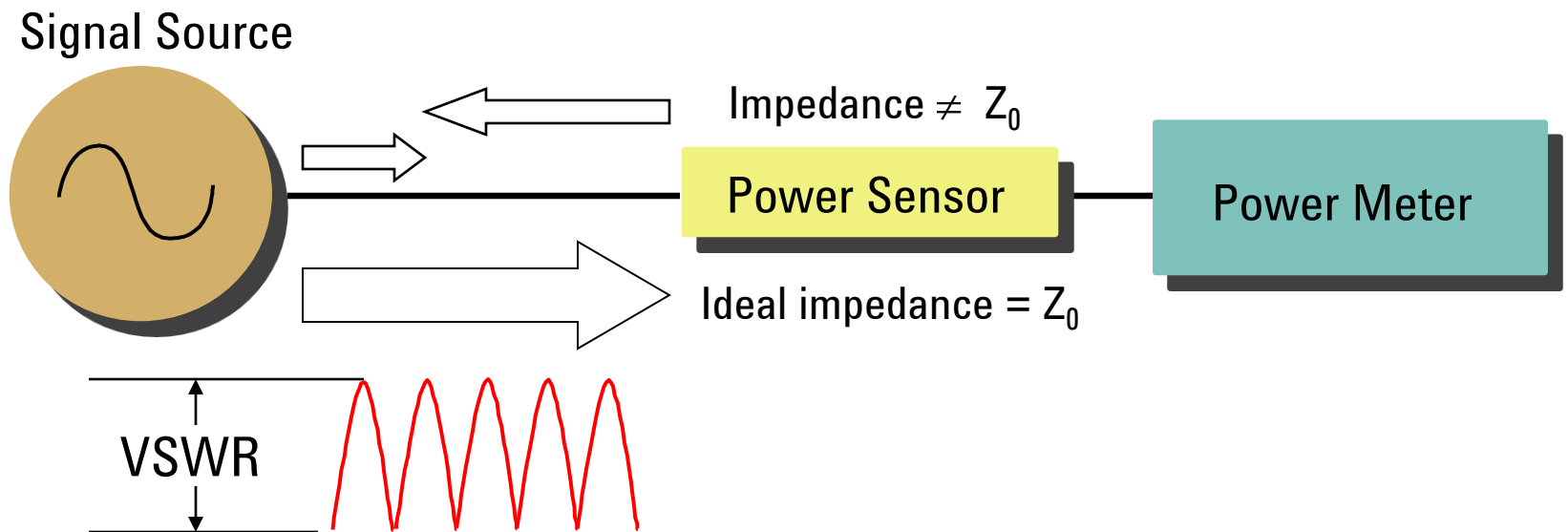

# Thank you!



## Adolfo Del Solar

Application Engineer  
[adolfo\\_del-solar@agilent.com](mailto:adolfo_del-solar@agilent.com)



## Agilent Technologies